

# The Instruction Fetch Unit

MO801

Rodolfo Azevedo

# Concepts check

1. What are the first steps to run one instruction?
2. Describe scenarios where you will need branch prediction
3. Why branch prediction?
4. Consider the branch predictor as a black box, what are the inputs and the outputs?

# Fetch Pipeline

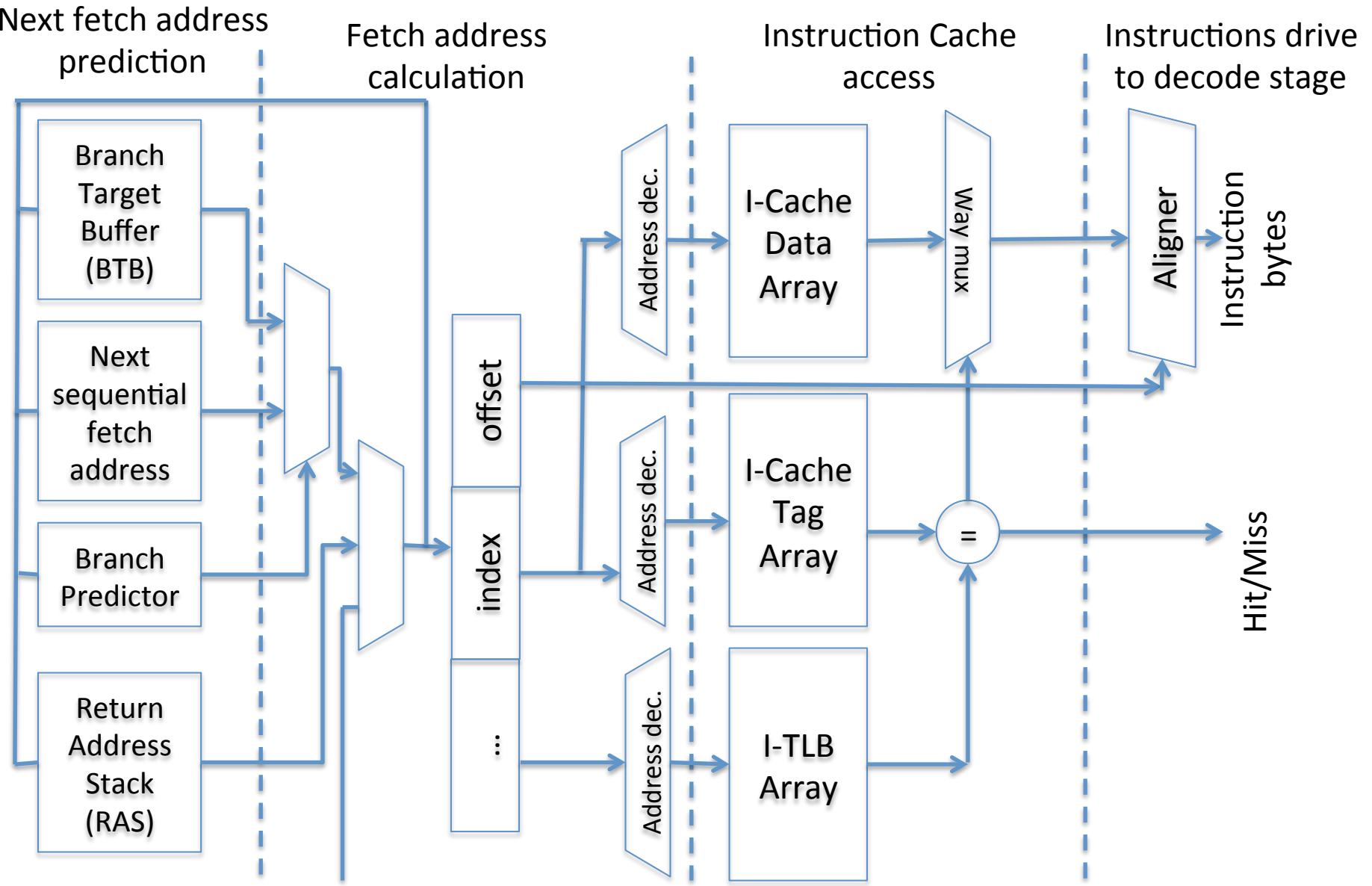

# Instruction Cache

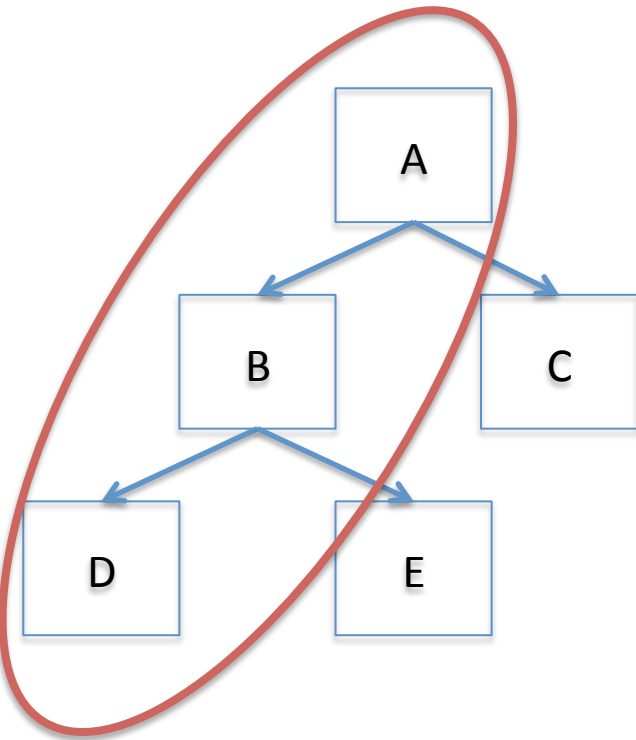

Dynamic path

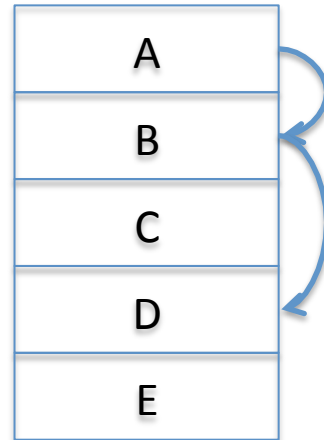

Conventional cache

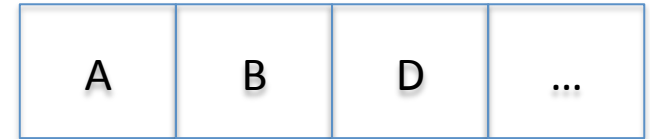

Trace cache

# Branch Target Buffer

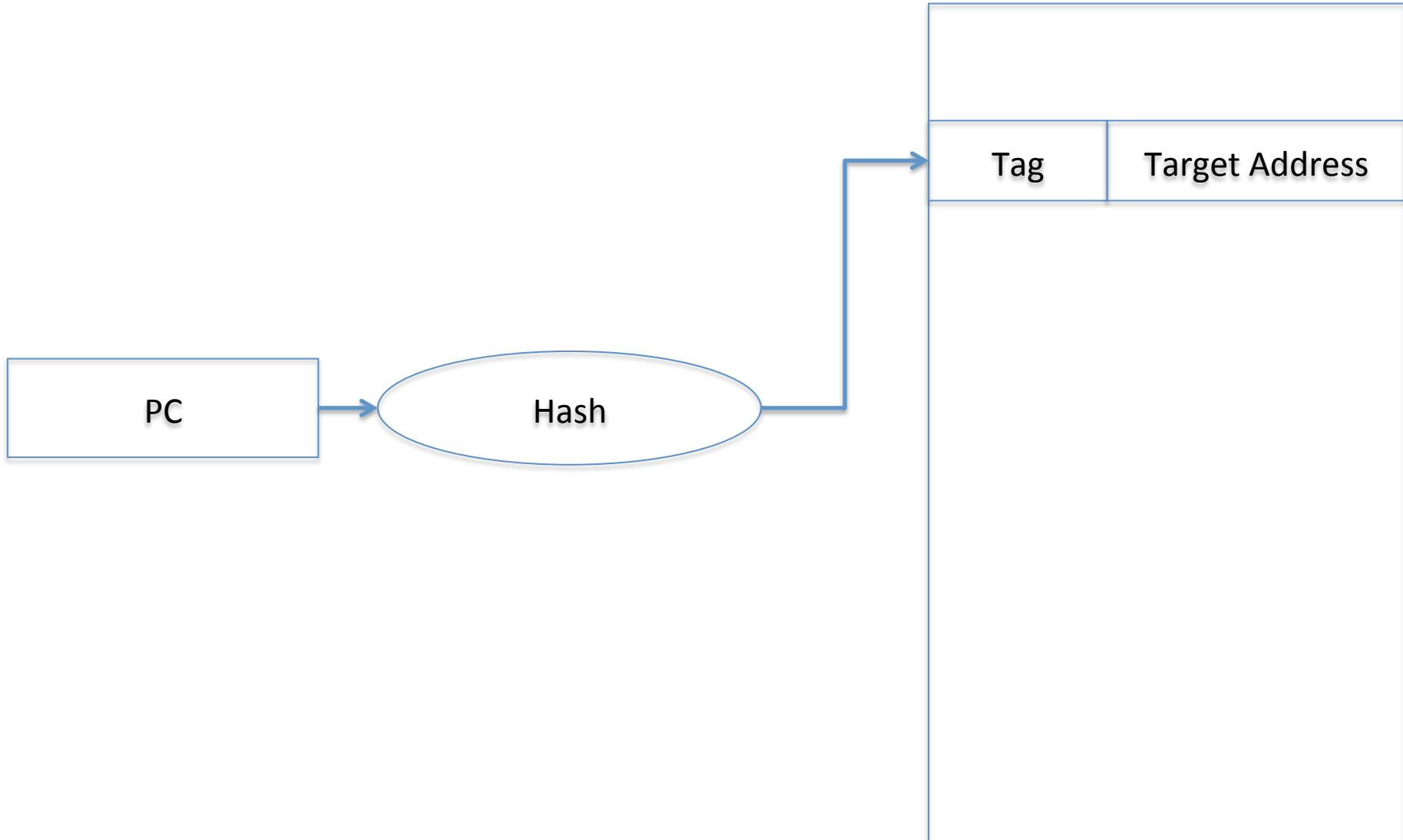

# Return Address Stack

- Uses the call trace to select the return address
- A few tens entries
- Lose the last entry in case of overflow

# Branch Predictor

- Static Prediction
  - Uses one bit in the instruction
- Dynamic Prediction
  - Local predictor
  - Correlating predictor (gshare)
- Hybrid Predictors
- Joined together with BTB