



MC 613

IC/Unicamp

2013s1

Prof Guido Araújo

Prof Mario Côrtes

Component, Library e Package

Tópicos

- Construções de VHDL
 - Implementação de circuitos hierárquicos com Component
 - Ilustração com Mux4:1 e Mux16:1
 - Alternativas: com ou sem Package
 - Libraries
- Implementação no Quartus e sistema de arquivos



MUX 4:1 – VHDL

```
LIBRARY ieee ;
USE ieee.std_logic_1164.all ;

ENTITY mux4to1 IS
    PORT (w0, w1, w2, w3: IN    STD_LOGIC ;
          s: IN STD_LOGIC_VECTOR(1 DOWNTO 0) ;
          f: OUT STD_LOGIC ) ;
END mux4to1 ;

ARCHITECTURE Behavior OF mux4to1 IS
BEGIN
    WITH s SELECT
        f <= w0 WHEN "00",
            w1 WHEN "01",
            w2 WHEN "10",
            w3 WHEN OTHERS ;
END Behavior ;
```

Mux 16:1 a partir de Mux 4:1

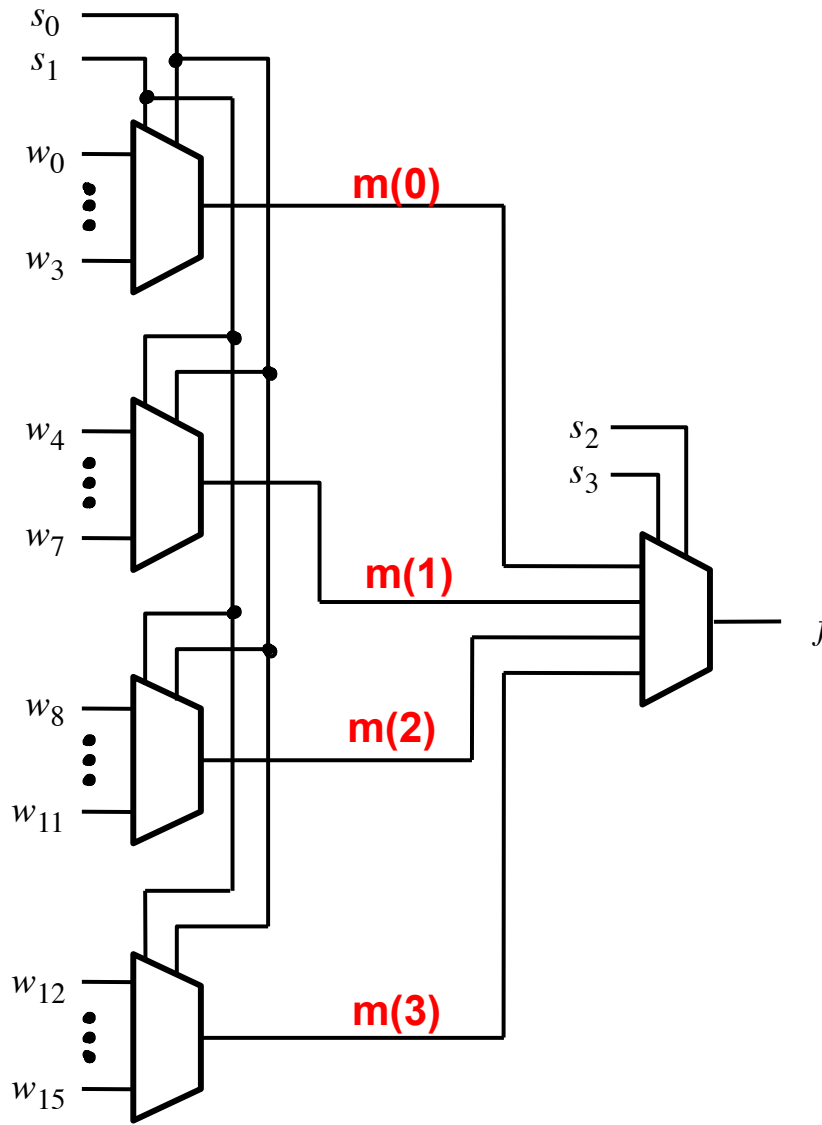

Alternativas:
com ou sem Package



Sem Package – Library e Entity

```
LIBRARY ieee ;
USE ieee.std_logic_1164.all ;

ENTITY mux16to1 IS
    PORT (w : IN  STD_LOGIC_VECTOR(0 TO 15) ;
          s : IN  STD_LOGIC_VECTOR(3 DOWNTO 0) ;
          f : OUT         STD_LOGIC ) ;
END mux16to1 ;
```



Sem Package – Architecture

ARCHITECTURE Structure OF mux16to1 IS

```
SIGNAL m : STD_LOGIC_VECTOR(0 TO 3) ;
```

```
COMPONENT mux4to1
```

```
    PORT ( w0, w1, w2, w3: IN      STD_LOGIC ;
```

```
          s: IN  STD_LOGIC_VECTOR(1 DOWNT0 0) ;
```

```
          f: OUT      STD_LOGIC ) ;
```

```
END COMPONENT ;
```

BEGIN

```
Mux1: mux4to1 PORT MAP
```

```
    ( w(0), w(1), w(2), w(3), s(1 DOWNT0 0), m(0) ) ;
```

```
Mux2: mux4to1 PORT MAP
```

```
    ( w(4), w(5), w(6), w(7), s(1 DOWNT0 0), m(1) ) ;
```

```
Mux3: mux4to1 PORT MAP
```

```
    ( w(8), w(9), w(10), w(11), s(1 DOWNT0 0), m(2) ) ;
```

```
Mux4: mux4to1 PORT MAP
```

```
    ( w(12), w(13), w(14), w(15), s(1 DOWNT0 0), m(3) ) ;
```

```
Mux5: mux4to1 PORT MAP
```

```
    ( m(0), m(1), m(2), m(3), s(3 DOWNT0 2), f ) ;
```

END Structure ;



Sem Package – arquivos de projeto

- Neste exemplo
- Todos os arquivos no mesmo diretório
 - Mux16to1.vhd
 - Mux4to1.vhd



Com Package – Declaração

```
LIBRARY ieee ;  
USE ieee.std_logic_1164.all ;  
PACKAGE mux4to1_package IS  
  COMPONENT mux4to1  
    PORT ( w0, w1, w2, w3: IN      STD_LOGIC ;  
          s: IN STD_LOGIC_VECTOR(1 DOWNTO 0) ;  
          f: OUT      STD_LOGIC ) ;  
  END COMPONENT ;  
END mux4to1_package ;
```

Neste exemplo:

- Um arquivo .vhd contem um ou mais packages
- Cada package pode listar um ou mais componentes



Com Package – Library e Entity

Usa o pacote definido

```
LIBRARY ieee ;  
USE ieee.std_logic_1164.all ;  
LIBRARY work ;  
USE work.mux4to1_package.all ;  
  
ENTITY mux16to1 IS  
    PORT (w : IN STD_LOGIC_VECTOR(0 TO 15) ;  
          s : IN STD_LOGIC_VECTOR(3 DOWNT0 0) ;  
          f : OUT STD_LOGIC ) ;  
END mux16to1 ;
```



Com Package – Architecture

ARCHITECTURE Structure OF mux16to1 IS

SIGNAL m : STD_LOGIC_VECTOR(0 TO 3) ;

BEGIN

Mux1: mux4to1 PORT MAP

(w(0), w(1), w(2), w(3), s(1 DOWNT0 0), m(0)) ;

Mux2: mux4to1 PORT MAP

(w(4), w(5), w(6), w(7), s(1 DOWNT0 0), m(1)) ;

Mux3: mux4to1 PORT MAP

(w(8), w(9), w(10), w(11), s(1 DOWNT0 0),
m(2)) ;

Mux4: mux4to1 PORT MAP

(w(12), w(13), w(14), w(15), s(1 DOWNT0 0),
m(3)) ;

Mux5: mux4to1 PORT MAP

(m(0), m(1), m(2), m(3), s(3 DOWNT0 2), f) ;

END Structure ;



Implementação no Quartus – s/ package

- Todos os arquivos no diretório de trabalho

Implementação no Quartus – c/ package

- Criar arquivo <arquivo_packages_do_aluno>
 - Definição dos componentes
 - O nome da package pode ser diferente do nome do arquivo
 - Aqui: <packages_do_aluno>
- Criar diretório <biblioteca_do_aluno> com conteúdo:
 - Arquivos de definição de Package:<arquivo_packages_do_aluno>
 - Source files de componentes
- Informar o Quartus do uso da biblioteca
 - Assignment > Settings > Libraries
 - Adicionar diretório da biblioteca

Implementação no Quartus – c/ package

- No código VHDL
 - Incluir cláusulas no início
 - LIBRARY biblioteca_do_aluno
 - USE biblioteca_do_aluno. packages_do_aluno.all
- No projeto
 - Incluir o arquivo arquivo_packages_do_aluno.vhd no repositório do projeto
 - Assignment > Settings > Files
 - Adicionar arquivo

Nome do diretório da biblioteca

Nome da package dentro do arquivo